

INCASSI_BUILT-IN PARTS

R96715

Parte incasso / Built-in part



Parte incasso miscelatore monocomando vasca-doccia, deviatore automatico.

Built-in part - single lever bath-shower mixer with automatic diverter.

INCASSI_BUILT-IN PARTS

R96715

Disegno Complessivo / Overall Drawing

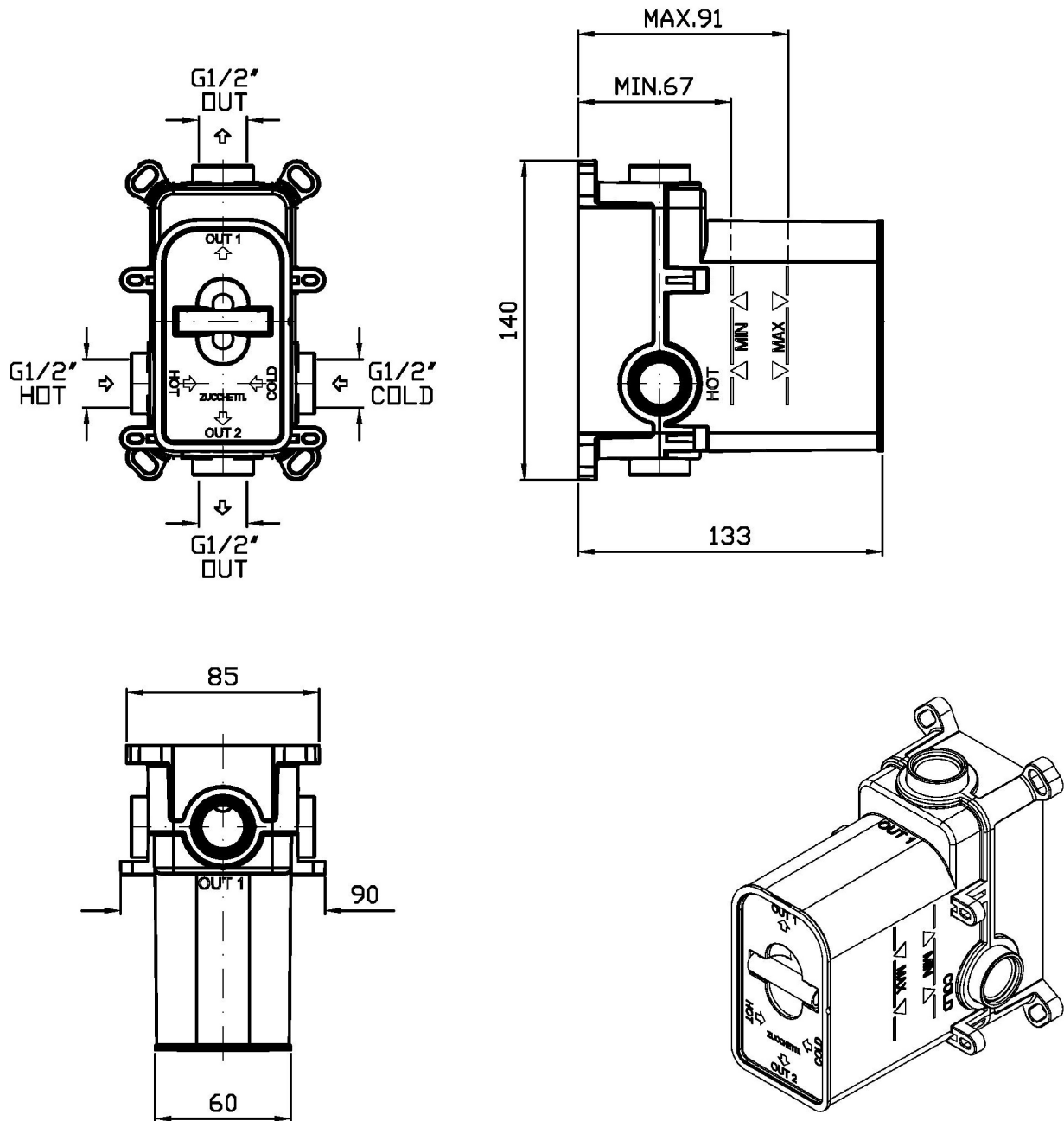

INCASSI_BUILT-IN PARTS

R96715 Portate / Flowrates (lt/min)

PRESSIONE PRESSURE	1 BAR	2 BAR	3 BAR	4 BAR	5 BAR
USCITA PRIMARIA PRIMARY OUTLET <i>P1</i>	15,8	22,5	28	32,5	36
USCITA SECONDARIA SECONDARY OUTLET <i>P2</i>	11,6	16,1	20	22,5	25,3
<i>P3</i>					
<i>P4</i>					
<i>P5</i>					

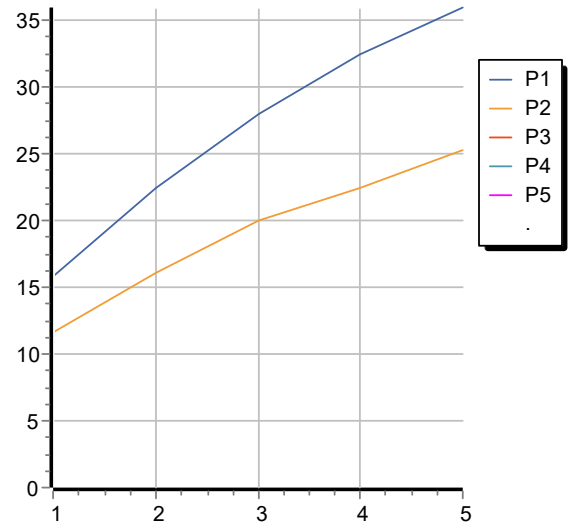

INCASSI_BUILT-IN PARTS

R96715 Pesì e Misure / Weights and Sizes

Peso (Kg) Weight (lb)	1,27 (Kg)	2,80 (lb)
Volume test (dc3) - (in3)	2,00 (dc3)	122,05 (in3)
h (mm) - (in)	140,00 (mm)	5,51 (in)
L1 (mm) - (in)	95,00 (mm)	3,74 (in)
L2 (mm) - (in)	150,00 (mm)	5,91 (in)

